



# CLEARPOINT

## NEURO

**SMARTFrame XG MRI-Guided Trajectory Frame**  
**INSTRUCTIONS FOR USE**

## Table of Contents

- I. Intended Use**
- II. Device Description**
- III. General Warnings and Precautions**
- IV. Use Instructions**
  - A. Preparation**
  - B. Mounting the Skull Mount Base and SMARTFrame XG Tower**
  - C. Mounting the Scalp Mount Base**
  - D. Attachment of the Thumb Wheel Extension Set**
  - E. Set Trajectory**
  - F. Exchanging the Cannula and Device Guides and Inserting Instruments**
  - G. Navigational Accuracy**
  - H. Procedures Utilizing the ClearPoint Neuro Stylet and Peel-Away Sheath**
    - I. Direct Insertion Procedures**
  - J. System Removal**
  - K. Storage and Technical Specifications**

## I. Intended Use

The ClearPoint System is intended to provide stereotactic guidance for the placement and operation of instruments or devices during planning and operation of neurological procedures within the MRI environment and in conjunction with MR imaging. The ClearPoint System is intended as an integral part of procedures that have traditionally used stereotactic methodology. These procedures include biopsies, catheter and electrode insertion including deep brain stimulation (DBS) lead placement. The System is intended for use only with 1.5 and 3.0 Tesla MRI scanners and MR Conditional implants and devices. The user should consult the “Navigational Accuracy” section of the User’s Guide to assess if the accuracy of the system is suitable for their needs.

**PRECAUTION:** The ClearPoint System can be used in conjunction with MR Conditional, but not MR Unsafe DBS Leads or DBS Leads for which MR Testing was not performed. Placement of MR Conditional deep brain stimulation (DBS) electrodes using the ClearPoint System should be performed in accordance with the instructions for use for such MR Conditional DBS electrodes. The user should carefully review the instructions for use for such MR Conditional DBS electrodes prior to undertaking a procedure with the ClearPoint System. Scanning a patient using conditions other than those given in the DBS electrode instructions for use may cause severe injury or death.

**Warning:** This device is intended for single use only. Contents of unopened, undamaged package are sterile. Do not re-sterilize.

**Caution:** Federal (U.S.) law restricts this device to sale by or on the order of a physician.

**Note:** For a complete procedure description, refer to ClearPoint System User’s Guide.

## II. Device Description

**Package Contents (one of the following):**

|                       |   |
|-----------------------|---|
| <b>NGS-SF-02-11</b>   | <b>SMARTFrame XG MRI-Guided Trajectory Frame</b><br>Stereotactic Frame, Skull Mount Base, Centering Ring, Dock, Standard Device Lock, Large Device Lock, Screwdriver, Roll Lock Screw w/ washer |
| <b>NGS-SF-04-11</b>   | <b>SMARTFrame XG MRI-Guided Trajectory Frame</b><br>Stereotactic Frame, Dock, Standard Device Lock, Large Device Lock, Screwdriver, Roll Lock Screw w/ washer                                   |
| <b>NGS-SF-02-11-5</b> | <b>SMARTFrame XG MRI-Guided Trajectory Frame, 5 Fr</b><br>Stereotactic Frame, Centering Ring, Dock, 5 Fr Device Lock, Large Device Lock, Screwdriver, Roll Lock Screw w/ washer                 |
| <b>NGS-SF-02-11-7</b> | <b>SMARTFrame XG MRI-Guided Trajectory Frame, 7 Fr</b><br>Stereotactic Frame, Centering Ring, Dock, 7 Fr Device Lock, Large Device Lock, Screwdriver, Roll Lock Screw w/ washer                 |

**Associated Devices:**

|                        |   |
|------------------------|---|
| <b>NGS-TE-01</b>       | <b>SMARTFrame Thumb Wheel Extension Set</b><br>Light Hand Controller  |
| <b>NGS-AK-01-11</b>    | <b>SMARTFrame Accessory Kit</b><br>4 Fr Stylet, 4 Fr Lancet, 4 Fr ID Peel-Away Sheath (2), Ruler, Depth Stop (2)  |
| <b>NGS-AK-01-11-5</b>  | <b>SMARTFrame Accessory Kit — 5 Fr</b><br>5 Fr Stylet, 5 Fr Lancet, 5 Fr ID Peel-Away Sheath (2), Ruler, Depth Stop (2)   |
| <b>NGS-AK-01-11-7</b>  | <b>SMARTFrame Accessory Kit — 7 Fr</b><br>7 Fr Stylet, 7 Fr Lancet, 7 Fr ID Peel-Away Sheath (2), Ruler, Depth Stop (2)   |
| <b>NGS-EAK-01-11-5</b> | <b>SMARTFrame Expanded Accessory Kit — 5 Fr</b><br>5 Fr Stylet, 5 Fr Lancet, 5 Fr ID Peel-Away Sheath (2), Ruler, Depth Stop (2), 2.5mm Device Guide, 5 Fr Device Lock, Large Device Dock |

|                        |   |
|------------------------|---|
| <b>NGS-EAK-01-11-7</b> | <b>SMARTFrame Expanded Accessory Kit — 7 Fr</b><br>7 Fr Stylet, 7 Fr Lancet, 7 Fr ID Peel-Away Sheath (2), Ruler, Depth Stop (2), 3.2mm Device Guide, 7 Fr Device Lock, Large Device Dock |
| <b>NGS-SG-01-11</b>    | <b>SMARTGrid MR Planning Grid</b><br>Marking Grid and Marking Tool  |
| <b>NGS-SM-01</b>       | <b>SMARTFrame Scalp Mount Base</b><br>Scalp Mount Base and centering tool   |
| <b>NGS-SK-01</b>       | <b>SMARTFrame Skull Mount Base</b><br>Skull Mount Base  |
| <b>NGS-DB-45</b>       | <b>SMARTTip MR Drill Kit, 4.5-mm</b><br>4.5-mm Drill Bit, 3.2-mm Drill Bit, Lancet, Depth Stop, Ruler   |
| <b>NGS-HD-01</b>       | <b>SMARTTwist MR Hand Drill</b><br>Hand Drill   |
| <b>NGS-XG-01</b>       | <b>SMARTFrame XG Exchangeable Device Guides</b><br>Device Guide, 3.4-mm, Device Guide, 14 GA  |
| <b>NGS-XG-02</b>       | <b>SMARTFrame XG Device Guide, 4.5 mm</b><br>4.5-mm Drill Guide   |
| <b>NGS-XG-03</b>       | <b>SmartFrame XG Device Guide, 2.5 mm</b><br>2.5-mm Device Guide  |
| <b>NGS-XG-04</b>       | <b>SmartFrame XG Device Guide, 3.2 mm</b><br>3.2-mm Device Guide  |
| <b>NGS-XG-05</b>       | <b>SMARTFrame XG Drill Guide, 6.0 mm</b><br>6.0-mm Drill Guide  |
| <b>NGS-XG-06</b>       | <b>SMARTFrame XG Drill Guide, 5.4 mm</b><br>5.4-mm Drill Guide, Depth Stop  |
| <b>NGS-GT-01</b>       | <b>SMARTFrame Guide Tubes</b><br>15 GA Guide Tube, 18 ga Guide Tube and 16 ga Guide Tube  |
| <b>NGS-GT-02</b>       | <b>SMARTFrame Guide Tubes .052" / 18 ga</b><br>.052" Guide Tubes that fit 18 ga devices (5)   |
| <b>NGS-GT-03</b>       | <b>SMARTFrame Guide Tubes .060" / 17 ga</b><br>.060" Guide Tubes that fit 17 ga devices (5)   |
| <b>NGS-GT-04</b>       | <b>SMARTFrame Guide Tubes .064" / CP Stylet</b><br>.064" Guide Tubes that fit ClearPoint Stylets (5)  |
| <b>NGS-GT-05</b>       | <b>SMARTFrame Guide Tubes .068" / 16 ga</b><br>.068" Guide Tubes that fit 16 ga devices (5)   |
| <b>NGS-GT-06</b>       | <b>SMARTFrame Guide Tubes .074" / 15 ga</b><br>.074" Guide Tubes that fit 15 ga devices (5)   |
| <b>NGS-PD-02-L</b>     | <b>MR Neuro Procedure Drape Tapered - Long</b><br>MR Neuro Procedure Drape Tapered, Marker Pen  |
| <b>NGS-PD-03-L</b>     | <b>MR Neuro Procedure Drape Tapered w/ Extension - Long</b><br>MR Neuro Procedure Drape Tapered w/ Extension, Marker Pen  |
| <b>NGS-PD-04</b>       | <b>MR Neuro Scanner Bore Drape w/ Extension</b><br>MR Neuro Scanner Bore Drape w/ Extension   |
| <b>NGS-PD-05</b>       | <b>MR Neuro Patient Drape</b><br>MR Neuro Patient Drape, Marker Pen, Cable Cover  |
| <b>NGS-RS-01</b>       | <b>SMARTFrame Skull Mount Rescue Screw</b><br>Skull Mount Rescue Bone Screws (3)  |

|                  |   |
|------------------|---|
| <b>NGS-RS-02</b> | <b>SMARTFrame Scalp Mount Rescue Screw – Long</b><br>Long Scalp Mount Rescue Bone Screws (3)  |
| <b>NGS-RS-03</b> | <b>SMARTFrame Scalp Mount Rescue Screw – Short</b><br>Short Scalp Mount Rescue Bone Screws (3)  |
| <b>NGS-BM-05</b> | <b>SMARTFrame MR Fiducial</b><br>MR Fiducials (5)   |
| <b>NGS-CG-01</b> | <b>Wharen Centering Guide</b><br>Wharen Centering Guide   |
| <b>NGS-TC-01</b> | <b>SMARTFrame XG Targeting Cannula</b><br>Targeting Cannula (1)   |
| <b>Note:</b>     | <b>If using devices other than those provided by ClearPoint Neuro, verify the device’s fit in the Guide Tube, Device Guide, or Drill Guide, and follow the manufacturer’s recommendations regarding MRI Compatibility prior to use.</b> |

The SMARTFrame XG (Exchangeable Guide) Tower is designed to be used with the Scalp Mount Base or the standard SMARTFrame Base, both of which are completely made of plastic, except for the bone screws and stand-off pins. The Tower (**see Figure 1**) attaches to the Base. The Tower, also completely made of plastic, is designed to provide multi-directional orientation adjustments to the Targeting Cannula, which is housed in the center of the Tower. The Targeting Cannula has a distal fluid filled sphere and a proximal fluid filled column that are both MRI visible. The Targeting Cannula also has a central lumen through which a Peel-Away Sheath and Stylet or other suitable devices can be placed and oriented. The Tower, when attached to the Scalp Mount Base, provides adjustments in the roll, pitch, X, and Y directions by turning the appropriate thumb wheels. The XG Tower has a Cap that can be removed so that the Targeting Cannula can be replaced with SMARTFrame XG Exchangeable Device Guides that accept different sized instruments after the trajectory to target is obtained and locked. **See Figure 2.**

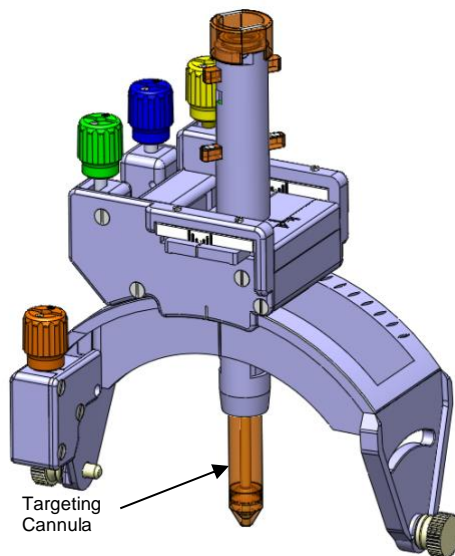

**Figure 1: SMARTFrame XG Tower and Targeting Cannula**

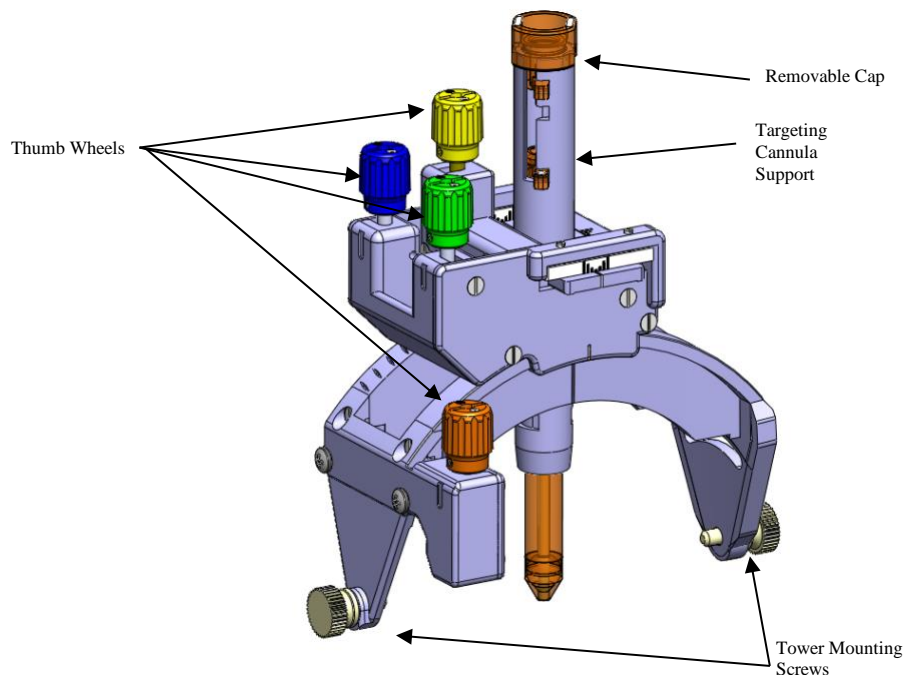

**Figure 2: SMARTFrame XG Tower Components**

The adjustments can be made by directly turning the thumb wheels or by using the ClearPoint Neuro Thumb Wheel Extension Set. The Thumb Wheel Extension Set is an approximately 60 cm long mechanism that can be attached to the SMARTFrame XG and utilized to rotate the thumb wheels while the patient is inside of the MR scanner bore.

### III. General Warnings and Precautions

The device is intended for single-use-only and is provided sterile. Do not re-sterilize.

- Warning:** Structures greater than 125 mm from the entry point should not be targeted, as placement accuracy beyond 125 mm has not been validated.
- Warning:** Do not use the ClearPoint System with instruments longer than 30 cm as the accuracy of the system has not been verified with instruments greater than this length.
- Warning:** Do not attach the Scalp Mount Base or Skull Mount Base Assembly to damaged or diseased bone. Only attach to stable bone to ensure a solid platform.
- Warning:** Before using the System on patients under the age of 16 years, measure the skull thickness on a CT scan to ensure that the system can be secured safely onto the skull.
- Warning:** When used with pediatric patients with open cranial sutures, take precautions to avoid placement that may result in placement of a screw into a cranial suture.
- Warning:** Verify scanner is within calibration prior to scanning.
- Warning:** Do not use a broken ClearPoint Neuro Stylet or Lancet.
- Warning:** All tools and ancillary equipment and devices must be MR compatible when performing scanning. When labeling is unclear, assume the device is not compatible. Always follow the manufacturer's instructions.
- Warning:** Prior to or after opening the SMARTFrame XG package, verify there is no leakage (fluid) visible on the Tower, or packaging. Do not use any device if leakage is identified.
- Warning:** There are no known and reliable means of cleaning, disinfecting, repairing, and sterilizing these devices that returns them to original specifications and renders them safe and effective for reuse.
- Caution:** Prior to or after opening the SMARTFrame XG package, verify there are no bubbles in the fluid filled sphere at the distal end of the Targeting Cannula. Do not use any device if such bubbles are identified.

- Caution:** It is recommended that additional sterile product be available for use.
- Caution:** The planned trajectory must allow for a 30 cm long device to be placed into the top of the assembled SMARTFrame XG without interfering with the bore of the MRI machine.
- Caution:** This device is to be used only by physicians trained by ClearPoint Neuro personnel.
- Caution:** When performing a burr hole procedure, A 14 mm burr hole is required for the ClearPoint Neuro SMARTFrame System for optimum range of motion for trajectory acquisition. Reduction in burr hole diameter will prevent the use of the Centering Tool, and could interfere with the range of motion during alignment of the Tower.
- Caution:** Do not place the Scalp or Skull Mount Base Assembly bone attachment screws in the cranial suture area.
- Caution:** The compatibility of neurological instruments and devices should be evaluated before use with the ClearPoint Neuro SMARTFrame XG System.
- Caution:** Never advance the ClearPoint Neuro Peel-Away Sheath into the brain without the supporting ClearPoint Neuro Stylet.
- Caution:** Do not advance a device through the Targeting Cannula or Peel-Away Sheath that is not resistant to compression and that may change in length with insertion. This may prevent accurate placement relative to the desired target.
- Caution:** Devices that are inserted through the Targeting Cannula (without the Peel-Away Sheath or one of the Device Guides) must be held from the point of insertion into the SMARTFrame XG until the device contacts the brain to prevent the device from advancing uncontrollably and possibly injuring the brain upon contact.
- Caution:** Do not apply more than 0.5 lb<sub>f</sub> to the device or any component while using the SMARTFrame XG System. Examples are force against the SMARTFrame XG when attached to the patient or the force to insert the Stylet or Lancet into the Peel-Away Sheath.
- Caution:** Orient the SMARTFrame on the patient's skull in such a manner as to prevent interference of the Thumb Wheel Extension Set with the bore of the scanner.
- Caution:** Use extreme caution when moving the scanner bore over the patient.
- Caution:** When used in an IMRIS suite, confirm that the Thumb Wheel Extension Sets have clearance and that the Head Coil cable is clear so that the IMRIS scanner can move freely without injuring the patient, damaging the Head Coil cable, or breaching the sterile field created by the Bore and Patient Drapes.
- Caution:** If using a Power Driver with an adjustable speed setting to secure the SmartFrame Base Bone Screws, use low speed settings to avoid breaking the Bone Screws.
- Note:** Safe disposal of the device: The device shall be treated as biohazardous materials and shall be disposed of accordingly per hospital policy.

#### General Precautions

- Handle all components using standard hospital sterile practices.
- Do not bend or kink the ClearPoint Neuro Peel-Away Sheath.
- Handle the ClearPoint Neuro Stylet and Lancet carefully to avoid breaking.
- Minimize any forces applied directly to the SMARTFrame.
- The following disposable components are MR Conditional: the SmartGrid, the Skull Mount Base, the Scalp Mount Base, the SMARTFrame XG, and the SMARTFrame Thumb Wheel Extension Set.

#### 1.5T & 3T Environment Compatibility:

Non-clinical testing has demonstrated the ClearPoint System is MR Conditional. It can be scanned safely under the following conditions:

Static magnetic field of 1.5 or 3 Tesla

Spatial gradient field of 5000 Gauss/cm

Maximum whole body averaged specific absorption rate (SAR) of 2.0 W/kg for 15 minutes of scanning.

In non-clinical testing, the ClearPoint System produced a temperature rise of less than 1°C at a maximum whole body averaged specific absorption rate (SAR) of 2.0 W/kg for 15 minutes of MR scanning in a 1.5T GE Signa MR scanner with Excite ver. 11.0 software and in a 3T Siemens Magnetom Trio MR scanner with ver. VB17 software.

## IV. Use Instructions

### A. Preparation

The SMARTFrame XG is packaged with a double sterile barrier: a tray with a sealed Tyvek lid is placed inside a sealed mylar/Tyvek pouch. Each SMARTFrame XG package contains the devices necessary for a uni-lateral procedure. A bi-lateral procedure will require opening two (2) SMARTFrame packages.

**Warning:** Do not use the SMARTFrame XG or any of the components if the packaging is damaged.

1. The Patient's head shall be prepared just prior to surgery by either shaving the entire head and applying incise tape or by shaving the area that will be covered with the Marking Grids and the area around them.
2. The patient's head is positioned outside the scanner at the head end of the scanner.
3. Position and secure the patient in an appropriate head fixation frame to immobilize the patient's head and select an appropriate imaging coil(s) to achieve desired image quality and provide access to the procedure site.

**Caution:** The patient's head must remain immobile throughout the procedure.

4. Install ClearPoint Neuro MR Neuro Procedure Drape following the Instructions for Use (IFU).
5. Determine and mark the location for burr-hole following the SmartGrid IFU.
6. If identifying points on the scalp with an MR Fiducial is desired, follow the SMARTFrame MR Fiducial IFU.

**Note:** **If using the Skull Mount Base, then skip Section C (Scalp Mount Base Mounting). If using the Scalp Mount Base, skip Section B (Skull Mount Base Mounting).**

### B. Mounting the Skull Mount Base and SMARTFrame XG Tower

1. Position the Centering Tool in the burr hole (not for burr holes smaller than 14 mm). If the burr hole is smaller than 14mm, the Centering Tool is not used.
2. Position the Base over the Centering Tool or visually center the Base over the burr hole with the single yellow fiducial marker in the up position. **See Figure 3.**
3. Using the supplied screw driver, mount the Base with the three (3) pre-mounted self-tapping screws to the skull.

**Note:** **In the event a replacement screw is required for securing the Base, additional Skull Mount Screws (3) can be used. See "Associated Devices" in Section II for ordering information on Rescue Screws.**

**Note:** A second set of screw mounting holes are located in the Base adjacent to the preloaded screw holes.

**Caution:** Only ClearPoint Neuro provided screws should be used for securing the Base.

**Note:** Check that the Base is secure and does not move. Confirm by feeling and observing for any movement while attempting to impart a rocking motion to the Base after mounting to the skull.



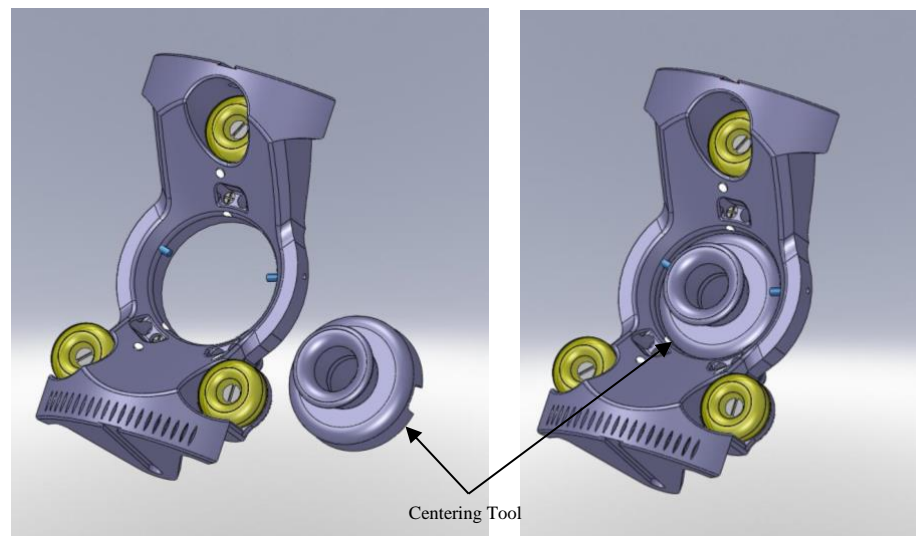

Figure 3: Base Mounting Orientation

4. Remove the Centering Tool if used.
5. Repeat the procedure for a second Base, if required for a bi-lateral procedure.
6. Once the Base(s) are attached to the skull, the SMARTFrame XG Tower is ready to be mounted.
7. Orient the Tower, relative to the Base, by placing the thumb wheels of the Tower toward the two fiducial marker side of the Base. **See Figure 4.** Be sure that each of the four thumb wheels is near the center of their ranges by looking at the range marker associated with each wheel.

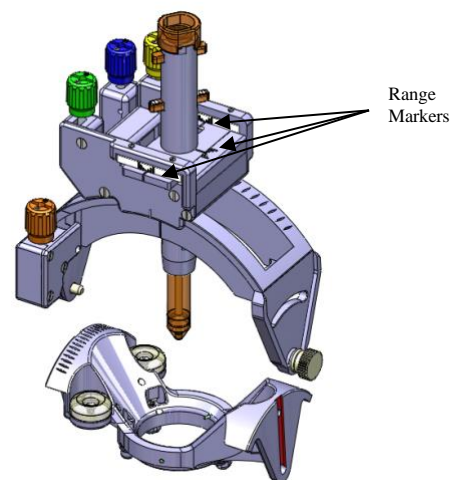

Figure 4

8. Mount the Tower onto the Base by first loosening then grasping the Tower Mounting Screws. Grasp the Tower by the top rectangular gear housing. Align each screw with the mating grooves on the Base. **See Figure 5a.** Slide the Tower into place and ensure screws seat into the mounting holes on the Base.  
**Caution:** Avoid applying pressure to the Tower Thumb Wheels while grasping the Tower. **See Figure 5b.**

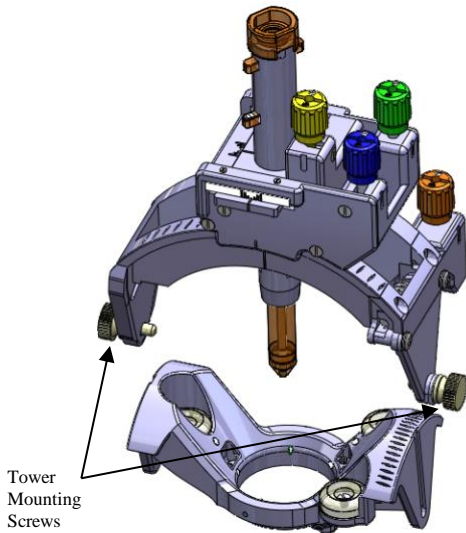

Figure 5a

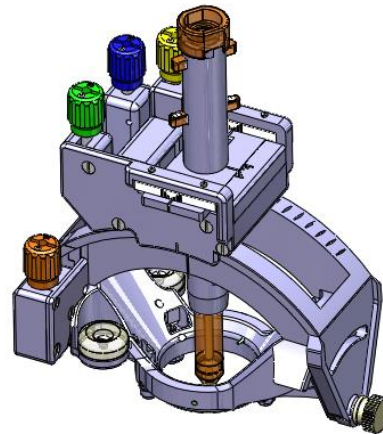

Figure 5b

**Caution:** For proper orientation of the Tower to the Base, ensure the orange thumb wheel of the tower is located on the side of the Base with the two yellow fiducial markers.

9. Tighten the two Tower Mounting Screws and confirm that the screws are completely seated with the Base.

**Warning:** The stability of the SMARTFrame XG should be checked prior to continuing. An unstable attachment of the SMARTFrame XG may result in an incorrect alignment to target or movement of the inserted device.

**Caution:** The Tower will mount securely to the Base. If the Tower moves relative to the Base, it is not mounted correctly.

10. Remove the Roll Lock Screw w/ washer from the SMARTFrame XG package to pre-mount in SMARTFrame XG. Screw in partially to the appropriate location on the SMARTFrame XG. See Figure 6. Ensure the Roll Lock Screw w/ washer is not tight. This screw will be tightened later in the procedure.

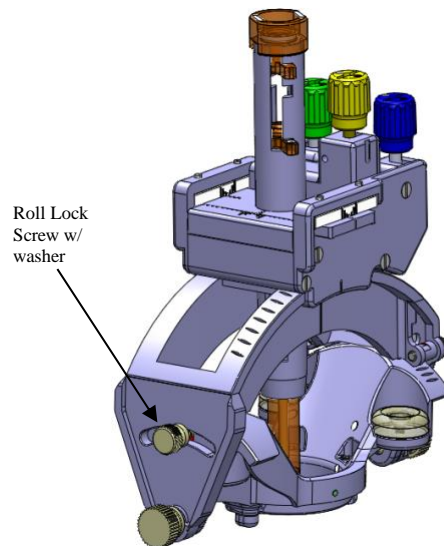

Figure 6: Roll Lock Screw w/ washer

**Caution:** The Roll Lock Screw w/ washer should not be tightened until final positioning is selected. If the Roll Lock Screw w/ washer is tight during roll adjustments, adjustments will be affected and may result in inappropriate alignment.

11. Confirm that the Targeting Cannula is in the forward position to begin the procedure. **See Figure 7.**

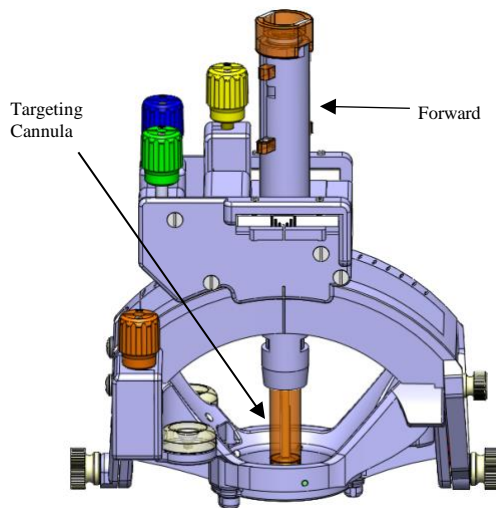

Figure 7: Targeting Cannula positioning and Tower/Base Orientation

**Caution:** Do not over tighten mounting screws.

### C. Mounting the Scalp Mount Base

**Note:** The Scalp Mount Base is intended for use with a maximum scalp thickness of 9 mm using the pre-loaded screws, and 11 mm using the Long Rescue Screws. Usage with thicker scalps may prevent the Scalp Mount Base from being stabilized properly.

**Note:** In order to use the Scalp Mount Base for scalp thicknesses from 9 to 11 mm, ensure that only Long Rescue Screws are used.

1. The Scalp Mount Base has four adjustable height support pins and three self-tapping bone screws. **See Figure 8.** The support pins have sharp tips. **See Figure 9.** They have small protective tubes covering them. Remove the tubes before proceeding.

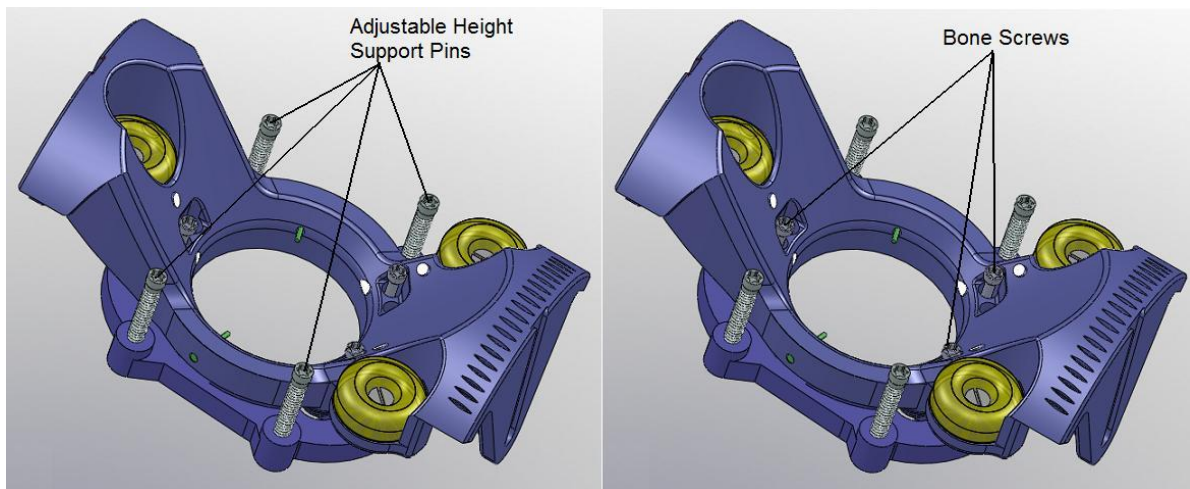
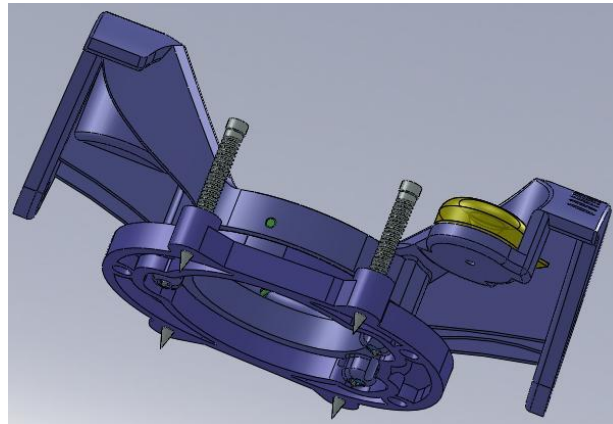

Figure 8: Adjustable Height Support Pins and Bone Screws for the Scalp Mount Base



**Figure 9: Sharp Adjustable Height Support Pins**

2. In order to center the Scalp Mount Base over the desired entry point, use one of three methods
  - Visually center the Base over the entry point
  - Use the MR Fiducial (REF NGS-BM-05) to center the Base over the entry point
  - Use the Wharen Guide (REF NGS-CG-01)
  
3. Once the Base is in position, begin securing the Bone Screws to the skull through the scalp. Using the screw driver supplied in the SMARTFrame Kit, mount the Scalp-Mount Base with the three (3) pre-mounted self-tapping screws to the skull.
 

**Note:** In the event a replacement screw is required for securing the Scalp-Mount Base, additional Scalp Mount Screws (3) can be provided. See “Associated Devices” in Section II for ordering information on Rescue Screws.

**Note:** A second set of screw mounting holes are located in the Scalp-Mount Base adjacent to the preloaded screw holes.

**Caution:** Only ClearPoint Neuro-provided screws should be used for securing the Scalp-Mount Base.
  
4. Secure the three bone screws into the skull. While screwing in the bone screws, check the security of the Base repeatedly, and check that the Base can lift off the scalp as it becomes secure in the skull.
  
5. Once the bone screws are secure in the skull, deploy the four support pins by screwing them down. The support pins will penetrate the scalp and will stop against the skull. The further they are deployed down, the more the Base will rise away from the scalp.
  
6. Repeatedly check the security of the Base during this operation. Once the Base is secure, proceed to the next step.
  
7. **Note:** Check that the Scalp-Mount Base is secure and does not move. Confirm by feeling and observing for any movement while attempting to impart a rocking motion to the Scalp Mount Base after mounting to the skull
  
8. The SMARTFrame XG is ready to be mounted to the Base. Follow instructions from Section B step 7 through step 11 for mounting the Tower to the Base.
 

**Note:** If creating an access hole using a drill/drill bit, then the pitch-roll and X-Y adjustments must be made prior to creating the access hole. DO NOT create the access hole prior to making pitch-roll and X-Y adjustments.

**Caution:** When performing the scan and alignment check, make sure no metallic devices are inserted into the SMARTFrame XG Targeting Cannula prior to scanning.

#### D. Attachment of the Thumb Wheel Extension Set

1. Remove the Thumb Wheel Extension Set from its sterile barrier package. **See Figure 10.**
  
2. Attach the distal ends (wings) of the Thumb Wheel Extension Set to the matching colored thumb wheels on the SMARTFrame XG. **See Figure 11.** You may need to rotate the Thumb Wheel Extension Set thumb wheels to properly orient the wings into the SMARTFrame thumb wheels. The wings should slide to the bottom of the thumb wheels and seat into place.

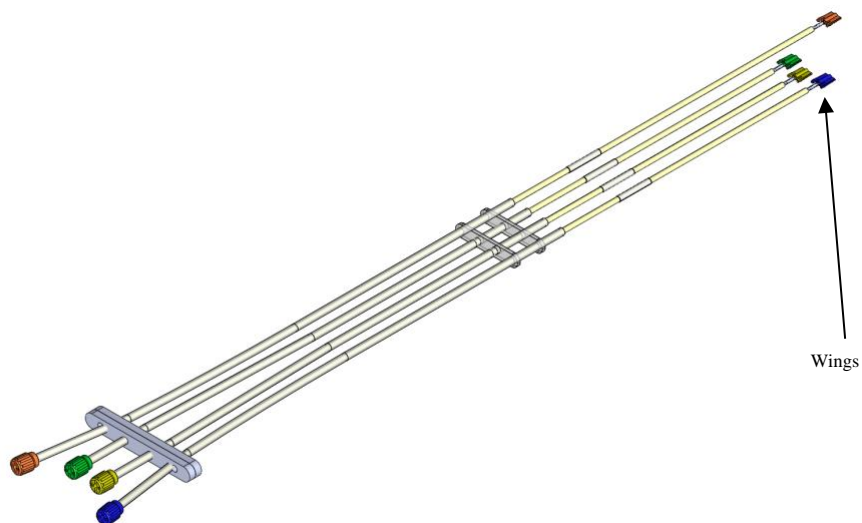

Figure 10: Thumb Wheel Extension

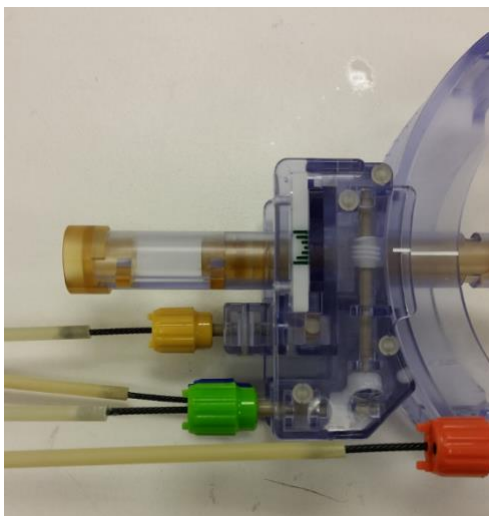

Figure 11: Attachment to Thumb Wheels

## E. Set Trajectory

**Note:** A clear understanding of and training to the ClearPoint User's Guide is required to complete the following steps.

1. Move the patient's head to the isocenter of the MR scanner and complete the appropriate scans to gain the information necessary to begin the "Navigate" portion of the procedure.

**Note:** If the ClearPoint Software cannot recognize the Targeting Cannula due to low fluid levels in the Targeting Cannula, replace the Targeting Cannula by following instructions from Section F step 3 through step 6.

2. The thumb wheels are color coded: Pitch is Blue, Roll is Orange, X is Yellow, and Y is Green. **See Figure 12.**



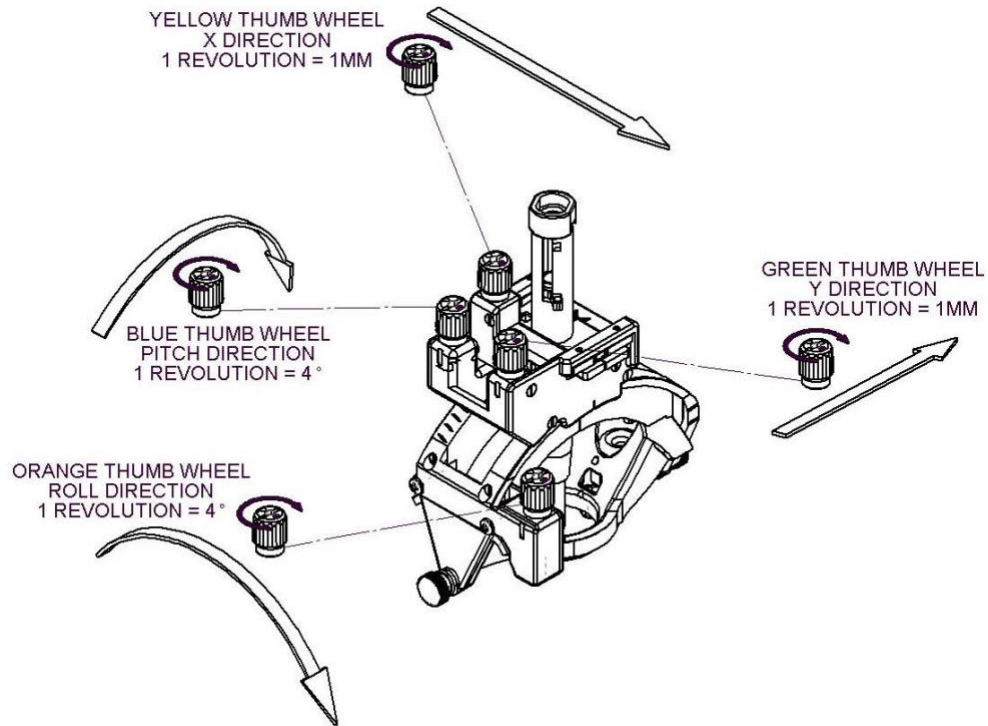

Figure 12: Tower Movements

3. Using the 'Required Adjustment' information from the ClearPoint Workstation, adjust the SMARTFrame XG to the desired trajectory. The SMARTFrame XG trajectory is adjusted by turning the four thumb wheels directly on the Tower or by turning the associated thumb wheels on the Thumb Wheel Extension Set.
4. The first/initial adjustments are made with the Pitch and Roll thumb wheels which will orient the SMARTFrame XG around the same pivot and entry point.
5. The Roll Lock Screw w/ washer must be tightened after the final roll adjustment is complete. **See Figure 6.** The Roll Lock Screw w/ washer must be loosened, for subsequent roll adjustments.
6. The final adjustments are made in the X or Y directions.

**Note:** Adjustments in the X and Y direction will result in a change of the pivot/entry point.

**Caution:** Any subsequent adjustments that include the use of the Pitch and Roll thumb wheels will require returning to the "Navigate" portion of the procedure/software.

**Note:** The Tower movements are limited to +/- 26 degrees in roll and +/- 33 degrees in pitch directions.

**Note:** The Tower movements are limited to +/- 2.5 mm in the X and Y directions.

**Caution:** Once the trajectory is established, ensure the Thumb Wheels do not move.

**Caution:** Care should be taken not to induce side loading of the Tower Assembly during device insertion.

The Targeting Cannula of the SMARTFrame XG is now aligned with the Target.

## F. Exchanging the Cannula and Device Guides and Inserting Instruments

1. Once the trajectory is set, use the roll locking screw to secure the position of the Frame in the pitch-roll direction.

**Caution:** Avoid exerting any lateral loads on the Tower during this process to avoid unintentionally shifting the Tower's trajectory.

2. If using the MR Drill Bit, the Targeting Cannula must be removed, and the appropriately sized Device Guide must be inserted into the Tower. Refer to the technical specifications section for a list of the different MR Drill Bits and the appropriately sized Device Guides for each.
3. Twist the Removable Cap so that the Tabs disengage from the TC Support Slots. **See Figure 13.** Then, pull the Cap away from the TC Support.

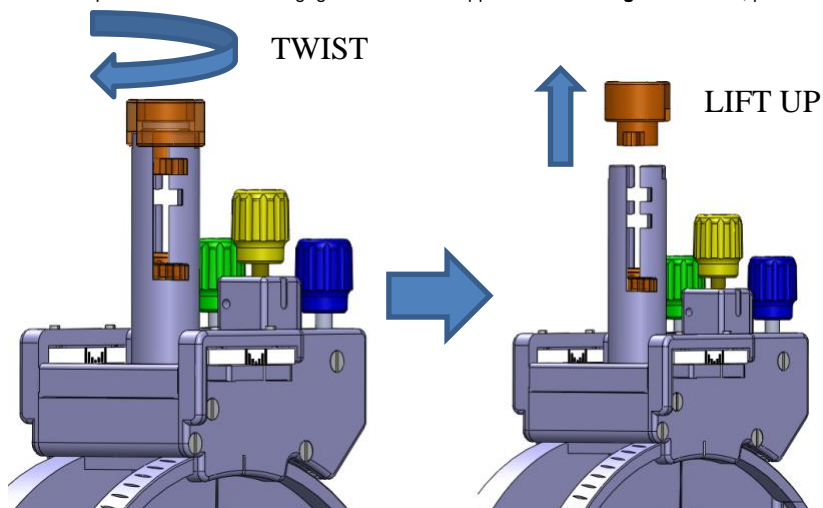

Figure 13: Removing the Targeting Cannula and TC Cap

4. Repeat the procedure to remove the Targeting Cannula.
5. Insert the desired Device Guide or replacement Targeting Cannula into the TC Support so that the tabs on the Device Guide or replacement Targeting Cannula fit into the long vertical slot on the TC Support. Then twist the Device Guide or replacement Targeting Cannula so the tabs engage the slots to lock it in position. **See Figure 14.**

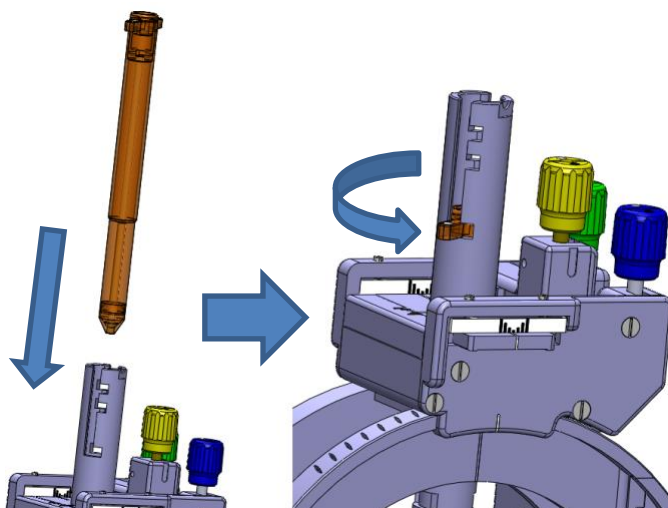

Figure 14: Inserting a Device Guide

6. Attach the Removable Cap by aligning the Cap's tabs with the slots in the TC Support, pressing down on the cap, and then twisting to lock the tabs into the horizontal slots. **See Figure 15.**

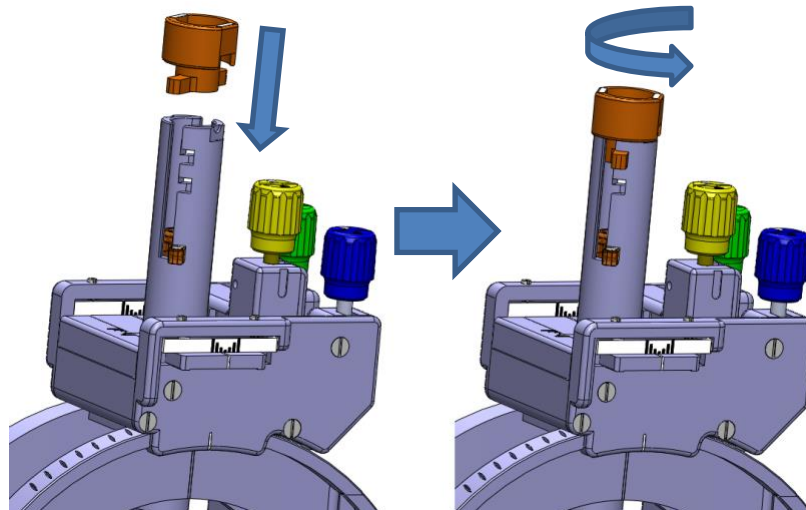

Figure 15: Reattaching the TC Cap

7. If using a SmartTip Drill Bit and SmartTwist MR Hand Drill to create the access hole, refer to the MR Hand Drill IFU.
8. Once the access hole has been created, choose the appropriate-sized Device Guide, and insert it into the TC Support as described in the steps above.
9. The Dock and Lock provided with the ATF may be used with the Removable Cap. The Dock provided with the Scalp Mount Base may be used with the Removable Cap. Make sure the Removable Cap is secured to the ATF before attaching the Dock to the Cap.
10. **If inserting the Peel-Away Sheath and Ceramic Stylet: Make sure to exchange the device guide for the Targeting Cannula prior to inserting the Peel-Away Sheath and Ceramic Stylet.**
11. The instrument may be inserted into the appropriate guide and advanced to target. During insertion, view the advancement of the instrument on the ClearPoint Workstation as appropriate. This insertion and visualization may be performed in 1/3 increments.
 

**Note:** The Targeting Cannula is MRI visible. The ClearPoint system can automatically display instrument trajectory during insertion when using the Targeting Cannula. The Device Guides are not MRI Visible. It is still possible to see the instrument during insertion as a void and manually check the trajectory.

## PROCEDURE OPTIONS

The remaining instructions are divided into procedural paths. Follow the instructions applicable to the device being used with the SMARTFrame.

### Procedures utilizing the ClearPoint Neuro Stylet and Peel-Away Sheath:

Procedures that require a Peel-Away Sheath with Stylet to confirm position by scanning and/or to create a path to the target. **See Section H.**

### Direct insertion procedures:

Procedures that do not need placement of the Peel-Away Sheath with Stylet. **See Section I.**

**Caution:** The compatibility of neurological instruments and devices should be evaluated before use with the ClearPoint Neuro SMARTFrame System and SMARTFrame Accessories.



## G. Navigational Accuracy

The device can provide a trajectory for placement of tools to targets within the brain. The radial (X-Y) plane trajectory error is < 1.5 mm at a 95% confidence interval.

**Caution:** The Z-plane or depth accuracy can only be verified by the user during real-time MR intraoperative imaging during placement of the instrument.

## H. Procedures Utilizing the ClearPoint Neuro Stylet and Peel-Away Sheath

The following covers procedures where the Peel-Away Sheath with Stylet (located in the SmartFrame Accessory Kit) is used to create a path to the target and/or scanning to confirm target acquisition.

**Warning:** Do not use the Accessory Kit if its packaging is damaged.

**Note:** The SmartFrame Accessory Kit is packaged with a double sterile barrier: a tray with a sealed Tyvek lid is placed inside a sealed mylar/Tyvek pouch. Identify the Stylet and the Lancet in the tray before removing them. The Stylet has a bull-nose tip, whereas the Lancet has a pointed tip. Make sure the Stylet is removed first.

**Note:** The 5 Fr / 7 Fr Lancet has a protective cover on the pointed tip. This should be removed before use.

### Peel-Away Sheath/Stylet Preparation and Insertion

1. Remove the Dock (See Figure 16) and Device Lock (see Figure 16) from the SMARTFrame package or from the SmartFrame Expanded Accessory Kit (as applicable).

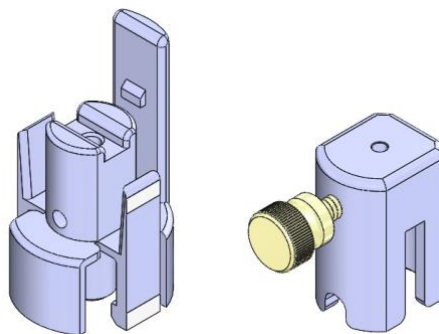
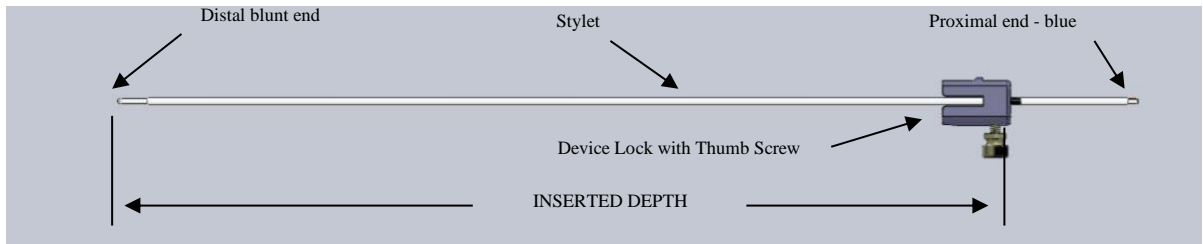

Figure 16: Dock (Left) and Device Lock (Right)

2. Remove a Peel-Away Sheath, the Stylet, and a Depth Stop from the Accessories package. Confirm that the Stylet has a bull nose tip.
  - Note:** The distal end of the Stylet has a bull nose tip and the proximal end of the Stylet is denoted with a blue marking.
  - Note:** When Sheath/Stylet insertion is used only for trajectory and position confirmation, it may be desired to stop short of the target, leaving undisturbed tissue for the final device. Subtract this distance “offset” from the depth value provided by the ClearPoint Workstation.
3. Mark the target’s depth on the Stylet using the Ruler and Marking Pen with the depth value from the ClearPoint Workstation.
4. Position the Device Lock on the depth mark on the Stylet and tighten the white thumb screw. The inserted depth of the Stylet is defined by the proximal side face of the Device Lock to the distal tip of the Stylet. Confirm the length using the Ruler. **See Figure 17.**
5. Optional: Position a Depth Stop on the Stylet; the inserted depth of the Stylet is defined by the distal side face of the Depth Stop to the distal tip of the Stylet. Slide the Stylet into Device Lock until Depth Stop rests on top of Device Lock. Then tighten the red thumb screw of the Depth Stop. Confirm the length using the Ruler. **See Figure 18.**
  - Caution:** Do not over tighten the red thumb screw on the Depth Stop or the white thumb screw on the Device Lock to avoid damaging or breaking the stylet.

**Warning:** Do not use a broken ClearPoint Neuro Stylet.



**Figure 17: Stylet and Device Lock**

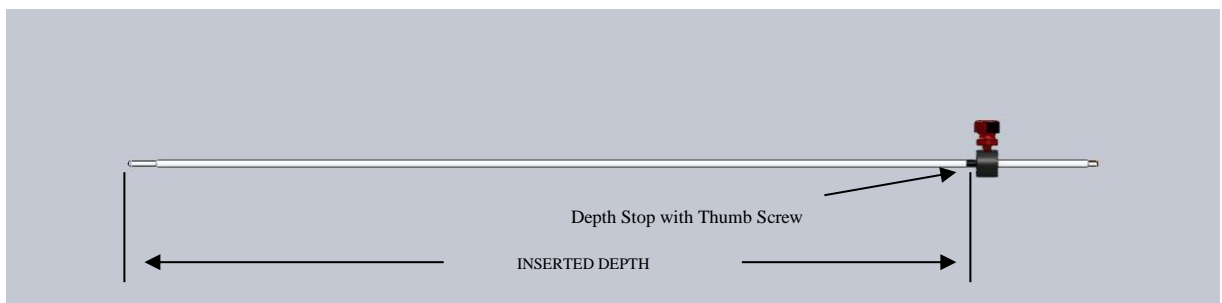

**Figure 18: Stylet and Depth Stop**

6. A Lancet has been provided as an alternate method to create an insertion point in the dura and/or pia. If using the Lancet, proceed to step 7. If not using the Lancet, proceed to step 14.
7. Remove the Lancet from the Accessory package.
 

**Caution:** The distal end of the Lancet has a pointed tip and the blunt proximal end is denoted with a green marking. Handle the Lancet near the proximal end. Avoid contacting the distal end.
8. Place a depth stop on the Lancet such that the distance from the distal point of the Lancet to the depth stop is approximately 1 inch greater than the distance from the inside of the dura or pia to the top of the ATF tower.
9. Remove one of the Peel-Away Sheaths from the Accessory Kit.
10. Separate the hub and peel away approximately 4 inches of the Sheath.
11. Insert the Lancet into the Peel-Away Sheath until the pointed end protrudes approximately one (1) to eight (8) millimeters. A slight resistance should be felt. If the Depth Stop interferes with the Sheath before the Lancet can be fully inserted, peel the sheath away further until the Lancet can be fully inserted.
12. By holding the exposed proximal end of the Lancet, insert the Lancet through the Targeting Cannula and through the burr hole until it contacts the dura or pia. Gently push on the Lancet until the dura and/or pia is pierced.
13. After piercing the dura and/or pia, withdraw the Lancet-Sheath Assembly from the Targeting Cannula.
14. Set aside the measured Stylet. Remove a Peel Away Sheath from the Accessory Kit and separate the hub and peel away approximately one (1) inch of the Sheath. Place the Peel-Away Sheath through the Dock.
15. Insert the peeled Sheath sides into the grooves of the Dock. **See Figure 19.**

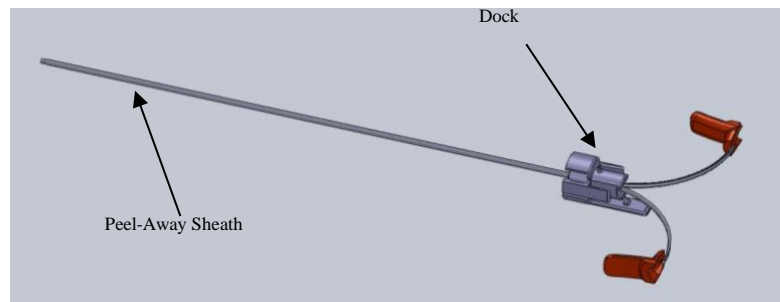

**Figure 19: Dock and Peel-Away Sheath**

16. Insert the Stylet into the Sheath. The distal end of the Stylet should protrude between one (1) and five (5) mm from the end of the Sheath. If it is not protruding, pull on both ends of the hub, peel the Sheath until the distal end of the Stylet protrudes between one (1) and five (5) mm. A slight resistance should be felt.

**Warning:** Verify that the Stylet is protruding from the Peel-Away Sheath prior to insertion.

17. Insert the Stylet into Dock until Device Lock mates and snap locks to Dock, making sure to orient the Device Lock such that the white thumb screw opposes the backboard extension piece of the dock. **See Figure 20.**

**Note:** While peeling the Sheath to expose the Stylet tip, the force should be steady and the peel smooth.

**Caution:** Do not over tighten the thumb screw on Device Lock or Depth Stop to avoid damaging the Stylet.

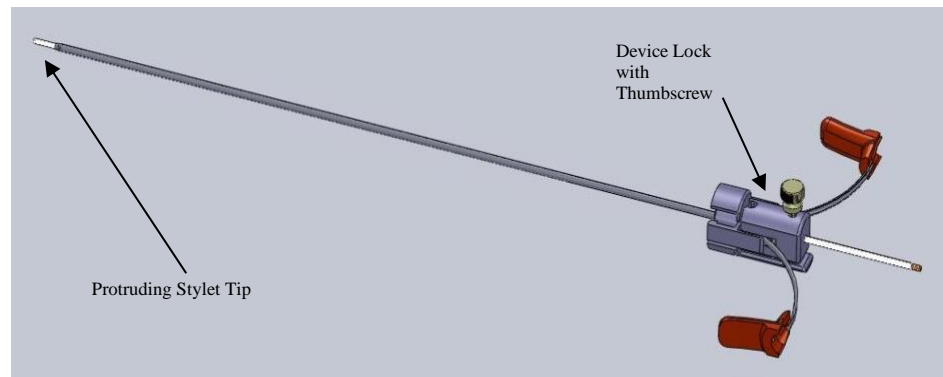

**Figure 20: Stylet Inserted into Peel-Away Sheath**

18. While the patient is in the scanner, insert the tip of the Stylet Assembly into the proximal end of the Targeting Cannula.
19. During insertion, view the advancement of the Stylet Assembly on the ClearPoint Workstation as appropriate. This insertion and visualization may be performed in 1/3 increments.
20. As insertion approaches the full measured target depth, orient the Dock such that the white lines of the Dock match up with the white lines on the flat aspects of the Device Guide Cap. **See Figure 21 for Stylet Assembly inserted into SMARTFrame XG.**

**Note:** To facilitate easier attachment to the Cap, it may be necessary to pinch the center of the Lock and Dock Assembly to flare out the Dock elements with white paint. **See Figure 27.**

The Peel-Away Sheath and Stylet Assembly is inserted to full target depth when it cannot be advanced further and fits securely over the Cap of the Device Guide.

21. Use the information from the ClearPoint Workstation to confirm the acceptability of the trajectory.

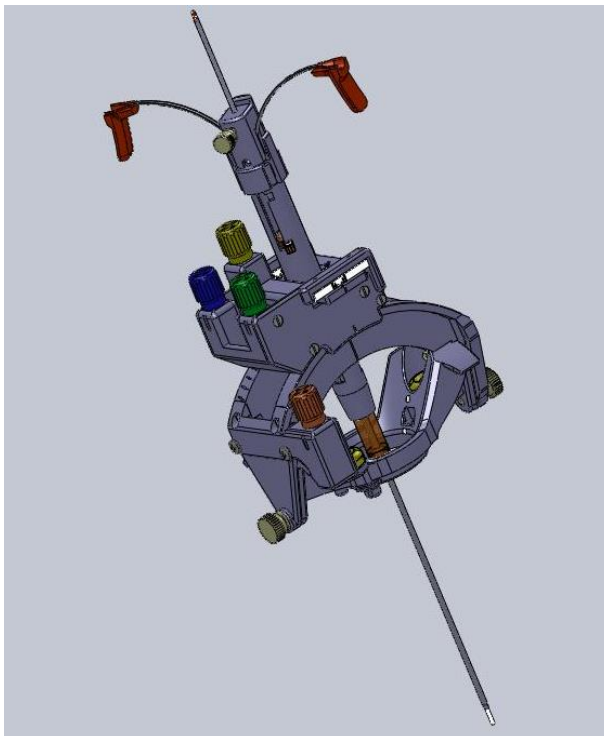

**Figure 21: SMARTFrame with Stylet Assembly inserted and snap locked into place.**

- Warning:** Do not adjust SMARTFrame XG while Stylet Assembly is inserted. If the trajectory needs to be modified, completely remove the Stylet Assembly prior to adjusting the SMARTFrame XG.
- Caution:** Do not over tighten thumb screw on Device Lock or Depth Stop to avoid damaging the Stylet.
- Note:** Devices that do not require the Peel-Away Sheath for insertion shall skip the steps below and go to Section I.

### Device Insertion through Peel-Away Sheath with 17 GA (.057") inner diameter.

- Caution:** If device to be inserted is not to be imaged, position patient's head outside the scanner at the head end of the scanner.
1. Loosen the Device Lock white thumb screw and remove the Stylet from the Peel-Away Sheath.  
Use the Depth Stop or marking pen to mark the inserted depth on the device.  
**Caution:** Do not over tighten the Depth Stop which could damage the device.
  2. Insert the device into the top of the Peel-Away Sheath through the Device Lock.  
**Caution:** Do not advance a device through the Targeting Cannula or Peel-Away Sheath that is not resistant to compression and that may change in length with insertion. This may prevent accurate placement relative to the desired target.
  3. Advance the device until the Depth Stop or the mark rests on top of the Device Lock.
  4. Tighten the white thumb screw of the Device Lock onto the device.  
**Caution:** Do not over tighten Device Lock which could damage the device.
  5. If appropriate, remove the Peel-Away Sheath by simultaneously pulling both ends of the split red hub until the Sheath is entirely removed in two pieces.

**Note:** Pull the Peel-Away Sheath handles straight during extraction. Twisting the sheath in the clockwise direction may cause the Cap to become loose. If the sheath must be twisted during extraction, twist in the counter-clockwise direction only. See Figures 22A, 22B and 22C.

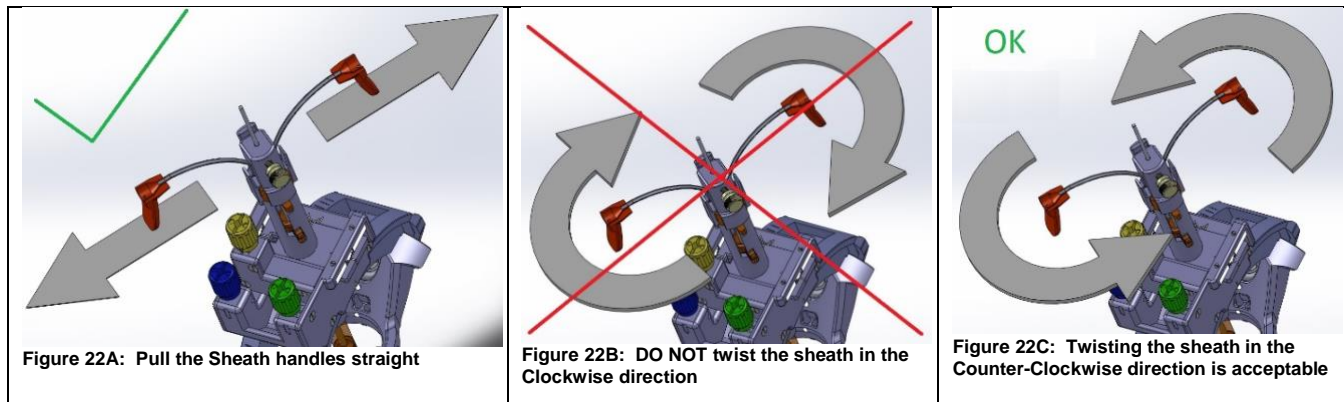

6. Retract the Targeting Cannula to the middle TC locking position. See Figure 23.

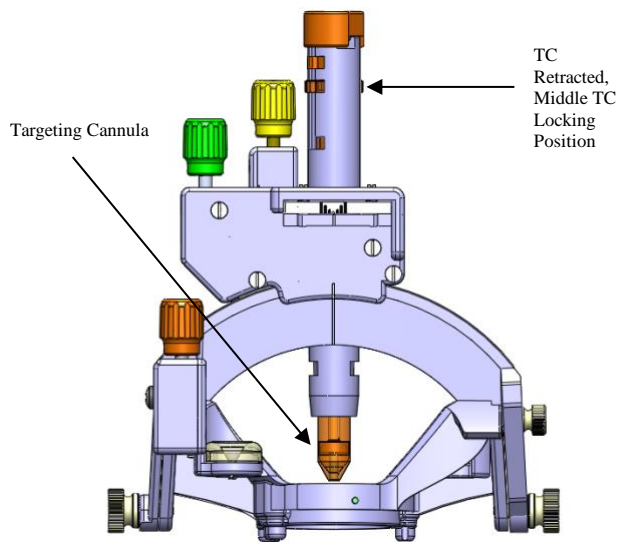

Figure 23: Targeting Cannula positioning

### Complete the Procedure

If not already complete, complete the procedure per the device manufacturer's IFU and standard surgical practices.

## I. Direct Insertion Procedures

**Note:** This section covers preparation and direct insertion of devices that are 1.24 mm to 2.34 mm

### Preparation and Insertion

**Note:** SMARTFrame Guide Tubes are used for providing compatibility with various diameter devices. See the chart below for the Guide Tubes required for the particular diameter device being used. Guide Tubes are color coded for identification.

**Note:** The Standard Device Lock is provided in the Tray with the SmartFrame XG. The 5 Fr and 7 Fr Device Locks are provided in the Tray with the SmartFrame XG-5 Fr and SmartFrame XG-7 Fr, respectively.

| Device Diameters |                        |       | Guide Tube                | Device Lock    |
|------------------|------------------------|-------|---------------------------|----------------|
| .050"            | 1.24 mm                | 18 GA | .052" Guide Tube (blue)   | Standard       |
| .058"            | 1.47 mm                | 17 GA | .060" Guide Tube (black)  | Standard       |
| .061"            | ClearPoint Stylet      |       | .064" Guide Tube (green)  | Standard       |
| .070"            | ClearPoint 5 Fr Stylet |       | .074" Guide Tube (white)  | 5 Fr           |
| .065"            | 1.65 mm                | 16 GA | .068" Guide Tube (orange) | Standard       |
| .072"            | 1.80 mm                | 15 GA | .074" Guide Tube (white)  | Large (yellow) |
| .083"            | 2.11 mm                | 14 GA | None required             | Large (yellow) |
| .092"            | 2.34 mm                | N/A   | None required             | Large (yellow) |
| .098"            | ClearPoint 7 Fr Stylet |       | None required             | 7 Fr           |

The Guide Tubes can be found in the **SMARTFrame Guide Tubes Kit** in 5 packs and can be distinguished by the colored bands (blue, orange, etc.) on the hub end. See **Figure 25**.

The Device Locks can be found in the SMARTFrame Tray. **The large Device Lock will be in its own pouch with a yellow marking on top for identification.** See **Figure 24**.

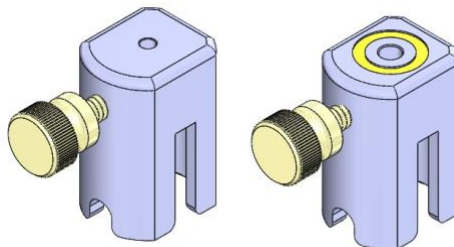

**Figure 24: Standard Device Lock (Left) and Large Device Lock (Right)**

**Note:** For device diameters from .084" to .098", the targeting cannula must be removed and replaced with an appropriately sized Device Guide from NGS-XG-01 or NGS-XG-03. Then the 7 Fr Device Lock, or Large Device Lock (yellow) would be used.

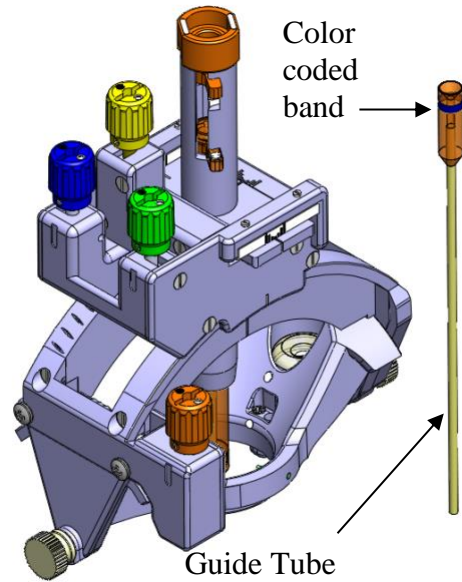

**Figure 25: Assembly before Insertion**

1. If the device to be inserted is not to be imaged, position the patient's head outside the scanner at the head end of the scanner.
2. If the Stylet Assembly was used previously, remove the Stylet Assembly including the Peel-Away Sheath, Device Lock, Stylet, and Depth Stop (if used) from SMARTFrame and separate these components from one another.
3. If necessary, select the appropriate Guide Tube (15 GA, 16 GA and 18 GA devices only) from the **SMARTFrame Guide Tubes Kit**.
  - 3.1 Insert the appropriate size Guide Tube into the Targeting Cannula as far as possible.
  - 3.2 Insert and snap lock the Dock in place. **See Figure 26.**

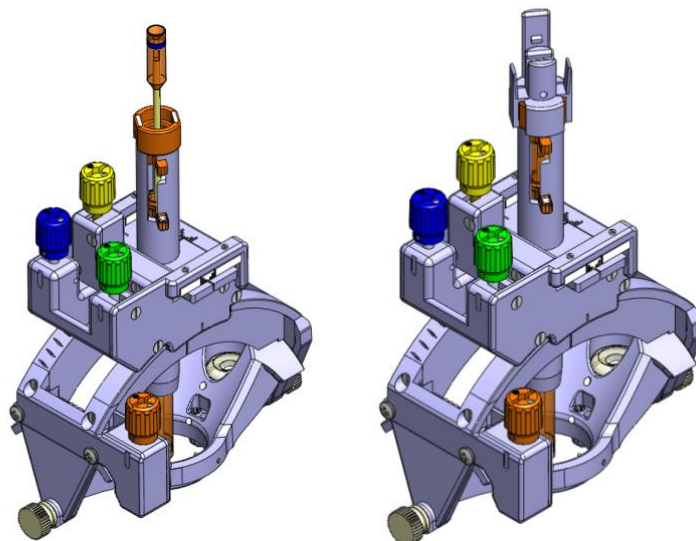

**Figure 26: Assembly after Insertion.**

4. Insert the device into the top of the Device Lock.
5. Set the inserted depth on the device from the distal end of the device to the top of the Device Lock using the Ruler. Lock the device to the Device Lock with the white thumb screw. Verify the measured inserted depth. Alternately, the bottom of the Depth Stop can be located at the appropriate position and locked into place on the device with the red thumb screw prior to inserting the device into the Device Lock. **See Figures 17 and 18 for similar placement of the Depth Stop or Device Lock onto Stylet.**

**Caution:** Do not over tighten the thumb screw which could damage the device.

### Insertion

1. Insert the device into the Dock through the Targeting Cannula or Device Guide until the Device Lock snaps and locks onto the Dock.  
**Caution:** Do not advance a device through the Targeting Cannula or Device Guide that is not resistant to compression and that may change in length with insertion. This may prevent accurate placement relative to the desired target.
2. If appropriate, retract Targeting Cannula or Device Guide and secure device based on manufacture's recommendations.
3. Perform the procedure as intended.
4. If appropriate, retract Targeting Cannula or Device Guide to the middle TC locking position and secure device based on manufacture's recommendations.
5. Perform the procedure as intended.

### Complete the Procedure

If not already complete, complete the procedure per the device manufacturer's IFU and standard medical practices.



## J. System Removal

**Note:** It is recommended that the system removal be performed with the patient's head outside of the scanner bore at the head end of the scanner.

**Warning:** Ensure device (if present) is secure per the manufacturer's instructions before removing SMARTFrame components or movement of the device could occur.

1. Remove the Thumb Wheel Extension Set by holding the appropriate Thumb Wheel on the SMARTFrame, while pulling gently on the corresponding Thumb Wheel Extension wing.
2. Loosen and remove the Depth Stop if used.
3. Loosen the white thumb screw on the Device Lock.
4. Remove the Dock and Device Lock Assembly by squeezing the clips to separate it from the SMARTFrame. **See Figure 27.**

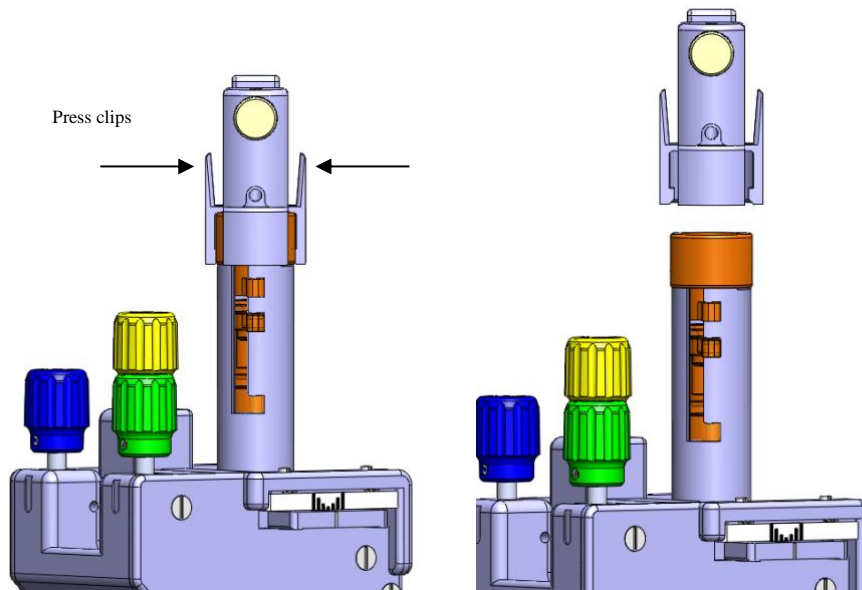

**Figure 27: Removing the Dock and Lock**

5. Slide the Dock and Device Lock Assembly completely off.
6. Remove the Roll Lock Screw w/ washer.
7. Loosen the Tower Mounting Screws and separate the Tower from the Base.
8. Remove the Base from the skull by unscrewing the titanium bone screws.

**Caution:** Avoid torquing the base during the removal of the base as this may break the remaining screws.

## K. Storage and Technical Specifications

### Storage

- Store in a cool dry place.

### Technical Specifications

- **SMARTFrame**

- **Device Accuracy**

The device can guide a rigid tool to the intended brain target with an error less than 1.5 mm.

- **Overall height (top of Device Lock) - 152.4 mm (6.00")**





















- **Instrument Sizes and Appropriate Device or Drill Guides**

| Instrument Size (mm) | Guide Inner Diameter (mm) | Guide Catalog Number |
|----------------------|---------------------------|----------------------|
| < 2.1                | N/A                       | N/A**                |
| 2.1 – 2.3            | 2.38 (Orange)             | NGS-XG-01            |
| 2.35 – 2.45          | 2.48 (Blue)               | NGS-XG-03            |
| 2.8 – 3.2            | 3.25 (Black)              | NGS-XG-04            |
| 3.0 – 3.4            | 3.58 (White)              | NGS-XG-01            |
| 3.5 – 4.5            | 4.65 (Green)              | NGS-XG-02            |
| 5.2 – 5.4            | 5.56                      | NGS-XG-06            |

\*\*For devices 2.1 mm or below in outer diameter, the Targeting Cannula may be used alone, or with the appropriate Guide Tube. See Section I for appropriate use of Guide Tubes with the SMARTFrame XG

- **Range of Movement**

| Orientation  | Travel   | Travel per 1 Rotation of Thumb Wheel | Thumb Wheel Color |
|--------------|----------|--------------------------------------|-------------------|
| <b>Roll</b>  | ± 26°    | 4°                                   | Orange            |
| <b>Pitch</b> | ± 33°    | 4°                                   | Blue              |
| <b>“X”</b>   | ± 2.5 mm | 1 mm                                 | Yellow            |
| <b>“Y”</b>   | ± 2.5 mm | 1 mm                                 | Green             |

| SYMBOL  | DEFINITION  | SYMBOL  | DEFINITION                      |
|---|---|---|---------------------------------|
|    | MR Safe   |    | MR Conditional                  |
|    | MR Unsafe   |    | Fragile, handle with care       |
|    | Consult instructions for use  |    | Single use                      |
|    | Do not resterilize  |    | Non sterile                     |
|   | Use by date   |   | Batch code                      |
|  | Catalogue number  |  | Sterilized using ethylene oxide |
|  | Do not use if the product sterilization barrier or its packaging is compromised |  | Sterilized through irradiation  |
|  | Keep away from sunlight   |  | Keep dry                        |
|  | Date of Manufacture   |  | Manufacturer                    |
|  | Not made with natural rubber latex  |  | Double sterile barrier system   |
|  | Non-pyrogenic   | <b>Rx Only</b><br>or<br><b>R Only</b>   | Prescription device             |

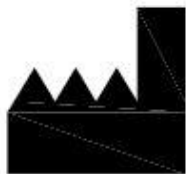

**Manufactured by:**

ClearPoint Neuro, Inc.  
6349 Paseo Del Lago  
Carlsbad, CA 92011  
USA  
949-900-6833

**THIS PAGE IS INTENTIONALLY LEFT BLANK**